

MULTIMODE OPTICAL TRANSCEIVER - QSFP 40G 850NM

BO25K859S2D

DESCRIPTION:

THE BLUEOPTICS® BO25K859S2D QSFP TRANSCEIVER IS A HIGH PERFORMANCE, COST EFFECTIVE MODULE SUPPORTING A DATARATE UP TO 40GBPS WITH 100 METER LINK LENGTH ON MULTI MODE FIBER. BLUEOPTICS® TRANSCEIVERS ARE 100% COMPLIANT WITH QSFP MULTI SOURCE AGREEMENT (MSA). ALL BLUEOPTICS® QSFP TRANSCEIVERS ARE ALWAYS EQUIPPED WITH DIGITAL DIAGNOSTIC FUNCTION COMPLIANT TO MSA SFF 8472.

USING DIGITAL DIAGNOSTIC, BLUEOPTICS® QSFP TRANSCEIVERS PROVIDE THE FOLLOWING REAL TIME INFORMATION:

- SUPPLY VOLTAGE
- LASER BIAS CURRENT
- LASER AVERAGE OUTPUT POWER
- LASER RECEIVED INPUT POWER
- TEMPERATURE

THE TRANSCEIVER CONSISTS OF FIVE SECTIONS: A 4 CHANNEL VCSEL TRANSMITTER, A 4 CHANNEL PIN PHOTODIODE, A 4 CHANNEL TRANS IMPEDANCE PREAMPLIFIER (TIA), THE LD DRIVER AND THE DIGITAL DIAGNOSTIC FUNCTION.



APPLICATIONS:

- 40G ETHERNET
- FIBRE CHANNEL
- INFINIBAND QDR
- DATA CENTER

WARRANTY:

EVERY BLUEOPTICS® TRANSCEIVER COMES WITH A 5 YEAR REPLACEMENT WARRANTY AND LIFETIME SUPPORT. FOR A WARRANTY INQUIRY, PLEASE CONTACT YOUR CBO SALES REPRESENTATIVE.

THIS WARRANTY COVERS THE FIRST USER OF THE EQUIPMENT ONLY.

FEATURES:

- 40GB/S SERIAL OPTICAL INTERFACE COMPLIANT TO 802.3BM 40GBASE-SR4
- UP TO 11.1GBPS DATA RATE PER CHANNEL
- VCSEL LASER TRANSMITTER
- PIN PHOTO DETECTOR
- HOT PLUGGABLE QSFP FOOTPRINT COMPLIANT TO SFF-8431
- MPO/PC TYPE PLUGGABLE OPTICAL INTERFACE
- 2 WIRE INTERFACE FOR MANAGEMENT
- METAL ENCLOSURE, FOR LOWER EMI
- ROHS COMPLIANT AND LEAD FREE
- SINGLE +3.3V POWER SUPPLY
- COMPLIANT WITH SFF 8472
- CASE OPERATING TEMPERATURE
 - COMMERCIAL: 0°C TO +70°C
 - EXTENDED: -10°C TO +80°C
 - INDUSTRIAL: -40°C TO +85°C



MULTIMODE OPTICAL TRANSCEIVER - QSFP 40G 850NM

BO25K859S2D

ORDER INFORMATION

Part No.	Temp.	DDM
BO25K859S2D	0°C to +70°C	√
BO25K859S2DEX	-10°C to +80°C	√
BO25K859S2DIN	-40°C to +80°C	√

REGULATORY COMPLIANCE

Feature	Standard	Co.
Electrostatic Discharge (ESD)	IEC/EN 61000-4-2	√
Electromagnetic Interference (EMI)	FCC Part 15 Class B EN 55022 Class B (CISPR 22A)	√
Laser Eye Safety	FDA 21CFR 1040.10, 1040.11 IEC/EN 60825 1, 2	Class 1 √
Component Recognition	IEC/EN 60950, UL	√
RoHS	2002/95/EC	√
EMC	EN61000-3	√

WARNINGS:

HANDLING PRECAUTIONS:

THIS DEVICE IS SUSCEPTIBLE TO DAMAGE AS A RESULT OF ELECTROSTATIC DISCHARGE (ESD). A STATIC FREE ENVIRONMENT IS HIGHLY RECOMMENDED.

LASER SAFETY:

EVEN SMALL RADIATION EMITTED BY LASER DEVICES CAN BE DANGEROUS TO HUMAN EYES AND LEAD TO PERMANENT EYE INJURIES. BE SURE TO AVOID EYE CONTACT WITH DIRECT OR INDIRECT RADIATION.

IMPORTANT NOTICE:

PERFORMANCE FIGURES, DATA AND ANY ILLUSTRATIVE MATERIAL PROVIDED IN THIS DATA SHEET ARE TYPICAL AND MUST BE SPECIFICALLY CONFIRMED IN WRITING BY CBO BEFORE THEY BECOME APPLICABLE TO ANY PARTICULAR ORDER OR CONTRACT. IN ACCORDANCE WITH THE CBO POLICY OF CONTINUOUS IMPROVEMENT SPECIFICATIONS MAY CHANGE WITHOUT NOTICE.

THE PUBLICATION OF INFORMATION IN THIS DATA SHEET DOES NOT IMPLY FREEDOM FROM PATENT OR OTHER PROTECTIVE RIGHTS OF CBO OR OTHERS.

FURTHER DETAILS ARE AVAILABLE FROM ANY CBO SALES REPRESENTATIVE.



MULTIMODE OPTICAL TRANSCEIVER - QSFP 40G 850NM

BO25K859S2D

INSTALLATION:

BEFORE INSTALLATION ATTACH AN ESD PREVENTIVE WRIST TO ENSURE NOT TO DAMAGE THE TRANSCEIVER OR HARDWARE.

BLUEOPTICS® BO25K859S2D CAN BE INSTALLED IN ANY SMALL FORM FACTOR PLUGGABLE+ (QSFP) PORT. YOU CAN INSTALL THE BO25K859S2D REGARDLESS IF THE SYSTEM IS POWERED ON OR OFF, BECAUSE IT IS HOT SWAPPABLE.

INSERT THE TRANSCEIVER INTO THE SFP PORT AND REMOVE THE DUST CAP.

YOU CAN NOW CONNECT YOUR CABLE.

1. ABSOLUTE MAXIMUM RATINGS

Parameter	Symbol	Min.	Typ.	Max.	Unit
Storage Temperature	Ts	-40		85	°C
Storage Ambient Humidity	HA	5		95	%

2. RECOMMENDED OPERATING CONDITIONS

Parameter	Symbol	Min.	Typ.	Max.	Unit	Note
		0		70		BO25K859S2D
		-10		80	°C	BO25K859S2DEX
		-40		85		BO25K859S2DIN
Ambient Humidity	HA	5		70	%	
Transmission Distance				100	M	
Coupled Fiber		Multi mode fiber				50/125µm MMF



MULTIMODE OPTICAL TRANSCEIVER - QSFP 40G 850NM

B025K859S2D

3. ELECTRICAL INTERFACE CHARACTERISTICS

Parameter	Symbol	Min.	Typ.	Max.	Unit	Note
Power Supply Voltage	Vcc	3.14	3.3	3.46	V	
Signal Input Voltage	Icc			200	mA	
Transmitter						
Input differential impedance	Rin		100		Ω	1
Single ended data input swing	VinT	-0.3		4.0	V	
Differential data input swing	Vin,pp	180		1000	mV	
Receiver						
Differential data output swing	Vout,pp	300		850	mV	2
Single-ended output voltage		-0.3		4.0	V	

NOTES:

1. CONNECTED DIRECTLY TO TX DATA INPUT PINS. AC COUPLED THEREAFTER.
2. INTO 100 Ω DIFFERENTIAL TERMINATION.

4. TRANSMITTER SPECIFICATIONS OPTICAL

Parameter	Symbol	Min.	Typ.	Max.	Unit	Note
Average Output Power per Lane	POUT	-6	-2.5	-1.2	dBm	
Average launch Power off per lane	POFF			-30	dBm	
Extinction Ratio	ER	3			dB	
Center Wavelength	λ_C	840	850	860	nm	
Transmitter and Dispersion Penalty	TDP			3.5	dB	
Spectral Width 20dB	σ			0.65	nm	
Optical Return Loss Tolerance	ORL			12	dB	
Transmitter Jitter (peak to peak)		Compliant with IEEE 802.3ba				



MULTIMODE OPTICAL TRANSCEIVER - QSFP 40G 850NM

B025K859S2D

5. RECEIVER SPECIFICATIONS OPTICAL

Parameter	Symbol	Min.	Typ.	Max.	Unit	Note
Receiver Sensitivity per Lane	PIN			-11.5	dBm	
Input Saturation Power (Overload)	PSAT	3.3			dBm	
Receiver Reflectance	PR			-26	dBm	

NOTES:

1. MEASURED WITH PRBS=2³¹ -1 NON RETURN TO ZERO.

6. QSFP TO HOST CONNECTOR PIN OUT

Pin	Symbol	Name / Description	Note
1	GND	Transmitter Ground (Common with Receiver Ground)	1
2	Tx2n	Transmitter Inverted Data Input	
3	Tx2p	Transmitter Non-Inverted Data output	
4	GND	Transmitter Ground (Common with Receiver Ground)	1
5	Tx4n	Transmitter Inverted Data Input	
6	Tx4p	Transmitter Non-Inverted Data output	
7	GND	Transmitter Ground (Common with Receiver Ground)	1
8	ModSelL	Module Select	
9	ResetL	Module Reset	
10	VccRx	3.3V Power Supply Receiver	2
11	SCL	2-Wire serial Interface Clock	
12	SDA	2-Wire serial Interface Data	
13	GND	Transmitter Ground (Common with Receiver Ground)	
14 GND	Rx3p	Receiver Non-Inverted Data Output	
15	Rx1n	Receiver Inverted Data Output	
16	GND	Transmitter Ground (Common with Receiver Ground)	



MULTIMODE OPTICAL TRANSCEIVER - QSFP 40G 850NM B025K859S2D

6. SFP+ TO HOST CONNECTOR PIN OUT

Pin	Symbol	Name / Description	Note
17	Rx1p	Receiver Non-Inverted Data Output	1
18	Rx1n	Receiver Inverted Data Output	
19	GND	Transmitter Ground (Common with Receiver Ground)	
20	GND	Transmitter Ground (Common with Receiver Ground)	1
21	Rx2n	Receiver Inverted Data Output	
22	Rx2p	Receiver Non-Inverted Data Output	
23	GND	Transmitter Ground (Common with Receiver Ground)	1
24	Rx4n	Receiver Inverted Data Output	1
25	Rx4p	Receiver Non-Inverted Data Output	
26	GND	Transmitter Ground (Common with Receiver Ground)	1
27	ModPrsl	Module Present	
28	IntL	Interrupt	
29	VccTx	3.3V power supply transmitter	2
30	Vcc1	3.3V power supply	2
31	LPMoDe	Low Power Mode	
32	GND	Transmitter Ground (Common with Receiver Ground)	1
33	Tx3p	Transmitter Non-Inverted Data Input	
34	Tx3n	Transmitter Inverted Data Output	
35	GND	Transmitter Ground (Common with Receiver Ground)	1
36	Tx1p	Transmitter Non-Inverted Data Input	
37	Tx1n	Transmitter Inverted Data Output	
38	GND	Transmitter Ground (Common with Receiver Ground)	1

MULTIMODE OPTICAL TRANSCEIVER - QSFP 40G 850NM

B025K859S2D

NOTES:

1. GND IS THE SYMBOL FOR SIGNAL AND SUPPLY (POWER) COMMON FOR QSFP MODULES. ALL ARE COMMON WITHIN THE QSFP MODULE AND ALL MODULE VOLTAGES ARE REFERENCED TO THIS POTENTIAL UNLESS OTHERWISE NOTED. CONNECT THESE DIRECTLY TO THE HOST BOARD SIGNAL COMMON GROUND PLANE.
2. VCCR_X, VCC₁ AND VCCT_X ARE THE RECEIVING AND TRANSMISSION POWER SUPPLIERS AND SHALL BE APPLIED CONCURRENTLY. RECOMMENDED HOST BOARD POWER SUPPLY FILTERING IS SHOWN BELOW. VCC_{RX}, VCC₁ AND VCC_{TX} MAY BE INTERNALLY CONNECTED WITHIN THE QSFP TRANSCEIVER MODULE IN ANY COMBINATION. THE CONNECTOR PINS ARE EACH RATED FOR A MAXIMUM CURRENT OF 500MA.

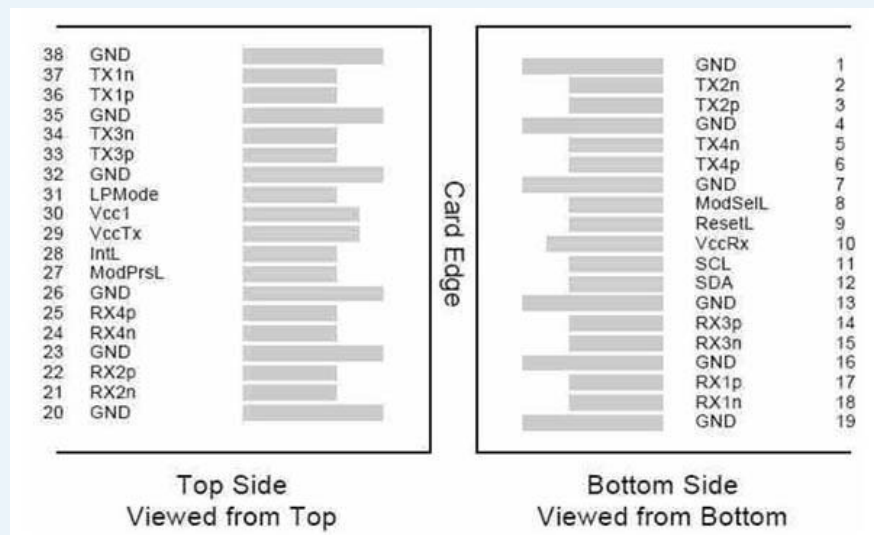

7. EEPROM INFORMATION

THE SFP MSA DEFINES A 256-BYTE MEMORY MAP IN EEPROM DESCRIBING THE TRANSCEIVERS CAPABILITIES, STANDARD INTERFACES, MANUFACTURER, AND OTHER INFORMATION, WHICH IS ACCESSIBLE OVER A 2 WIRE SERIAL INTERFACE AT THE 8-BIT ADDRESS 1010000X (A0H).

Data Address	Field Size (Bytes)	Name of Field	Description
128	1	Identifier	Formfactor
129	1	Ext. Identifier	
130	1	Connector	
131 - 138	8	Transceiver	Transmittter Code
139	1	Encoding	
140	1	BR, Nominal	Transceiver Speed



MULTIMODE OPTICAL TRANSCEIVER - QSFP 40G 850NM

B025K859S2D

Data Address	Field Size (Bytes)	Name of Field	Description
141	1	Extended RateSelect Compliance	Tags for Extended RateSelect compliance
142	1	Length (9µm) km	Max. link length in KM
143	1	Length (9µm) 100m	Max. link length in M
144	1	Length (50µm) 10m	Max. link length in M
145	1	Length(62.5µm)10m	Max. link length in M
146	1	Length (Copper)	Max. link length in M
147	1	Device Tech	Device technology
148 - 163	16	Vendor name	Vendor name - OEM
164	1	Extended Transceiver	Extended Transceiver Codes for InfiniBand
165 - 167	3	Vendor OUI	
168 - 183	16	Vendor PN	Product Number - depending on Part
184 - 185	2	Vendor rev	Vendor revision
186 - 187	2	Wavelength	Transceiver Wavelength
188 - 189	2	Wavelength tolerance	Guaranteed range of laser wavelength (+/- value) from Nominal wavelength (Wavelength Tol. = value/200 in nm)
190	1	Max Case Temp	Maximum Case Temperature in Degrees C
191	1	CC_BASE	Check code for Base ID Fields (addresses 128-190)
192 - 195	4	Options	Rate Select, TX Disable, TX Fault, LOS
196 - 211	16	Vendor SN	Part serial number
212 - 219	8	Vendor date code	Year, Month, Day
220	1	Diagnostic type	Diagnostics
221	1	Enhanced option	Indicates which optional enhanced features are implemented in the transceiver.
222	1	Reserved	Reserved
223	1	CC_EXT	Check code for the Extended ID Fields (addresses 192-222)
224 - 255	32	Vendor Specific	Vendor Specific EEPROM



MULTIMODE OPTICAL TRANSCEIVER - QSFP 40G 850NM

B025K859S2D

8. DIGITAL DIAGNOSTICS / DIGITAL OPTICAL MONITORING

THE TRANSCEIVER PROVIDES SERIAL ID MEMORY CONTENTS AND DIAGNOSTIC INFORMATION ABOUT THE PRESENT OPERATING CONDITIONS BY THE 2-WIRE SERIAL INTERFACE (SCL, SDA).

THE DIAGNOSTIC INFORMATION WITH INTERNAL CALIBRATION OR EXTERNAL CALIBRATION ARE ALL IMPLEMENTED, INCLUDING RECEIVED POWER MONITORING, TRANSMITTED POWER MONITORING, BIAS CURRENT MONITORING, SUPPLY VOLTAGE MONITORING AND TEMPERATURE MONITORING.

9. RECOMMENDED INTERFACE CIRCUIT

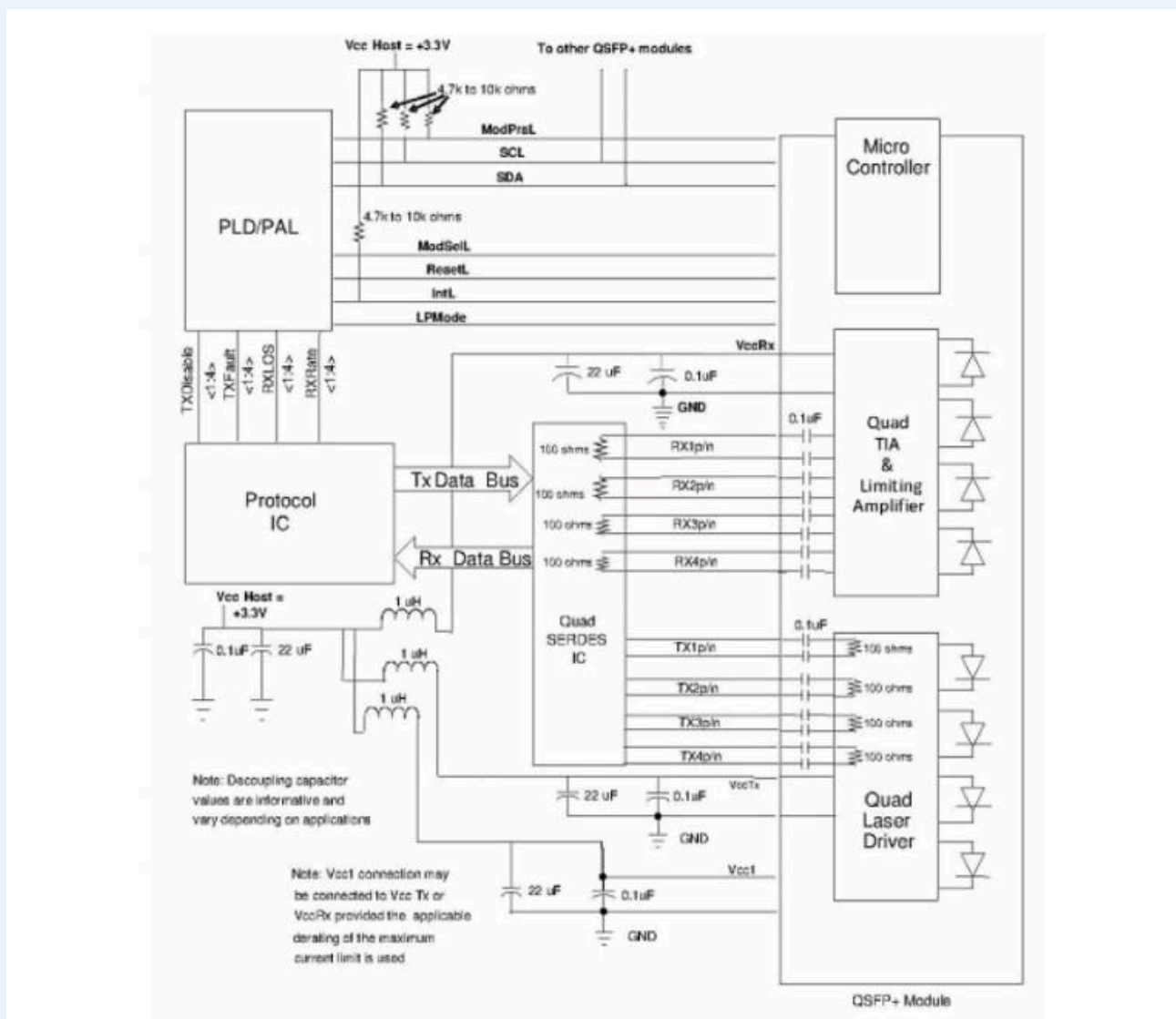



MULTIMODE OPTICAL TRANSCEIVER - QSFP 40G 850NM

B025K859S2D

10. MECHANICAL SPECIFICATIONS (UNIT: MM)

